

Dimensions: [mm]

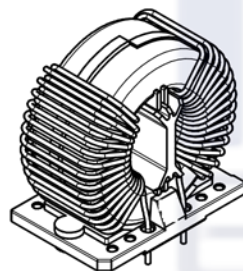

Scale - 1:1,5

Recommended Hole Pattern: [mm]

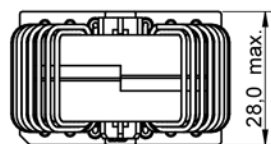
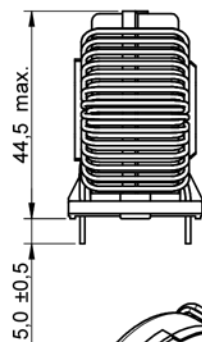
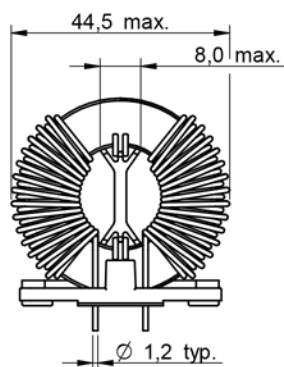
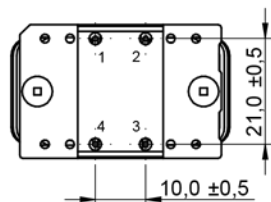
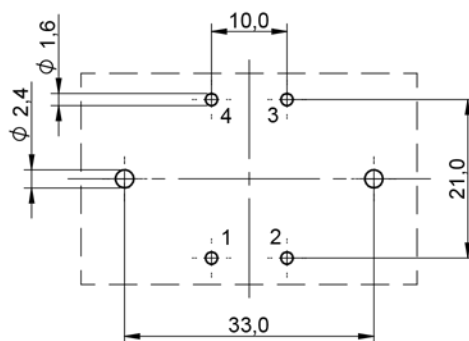

Scale - 1:1

Schematic:

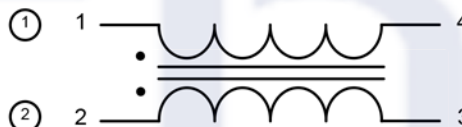

Electrical Properties:

| Properties | Test conditions | | Value | Unit | Tol. |
|-------------------------|---------------------|----------------------|-------|--------|------|
| Inductance | 10 kHz/ 0.1 mA | L | 2x3.4 | mH | ±30% |
| Rated Current | @ 70 °C | I _R | 9 | A | max. |
| DC Resistance | @ 20 °C | R _{DC max.} | 2x27 | mΩ | max. |
| Rated Voltage | 50 Hz | U _R | 760 | V (AC) | max. |
| Insulation Test Voltage | 50 Hz/ 5 mA/ 2 sec. | U _T | 3000 | V (AC) | max. |

General Information:

| | |
|--|----------------------|
| It is recommended that the temperature of the component does not exceed +125 °C under worst case conditions | |
| Ambient Temperature (referring to I _R) | -40 °C up to +85 °C |
| Storage Temperature (in original packaging) | -20 °C up to +60 °C |
| Operating Temperature | -40 °C up to +125 °C |
| Temperature Rise < 55K | |
| Test conditions of Electrical Properties: +20 °C, 33% RH if not specified differently | |
| Due to heavy weight, we recommend to fix the component on PCB with 2 self tapping screws: 2.2*x x= screw length, depends from PCB thickness | |

Shaanxi FKS Electronic Parts Import&Export Co.,Ltd.
 FKS(Xi'an) Electronic Technology Co.,Ltd.
 Address: B1 Building,Western Cloud Valley,Fengxi New Town,
 Xixian New Area,Xi'an City, Shaanxi Province,China.
 Tel: +86-29-8868 5333
 Fax: +86-29-8868 0913

FKS
Electronics



GENERAL TOLERANCE
DIN ISO 2768-1m

PROJECTION
METHOD

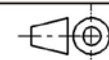

DESCRIPTION

**HV Common Mode
Power Line Choke**

ORDER CODE

FKS744831034090

SIZE
XXL

REVISION
001.002

STATUS
Valid

Typical Insertion Loss:

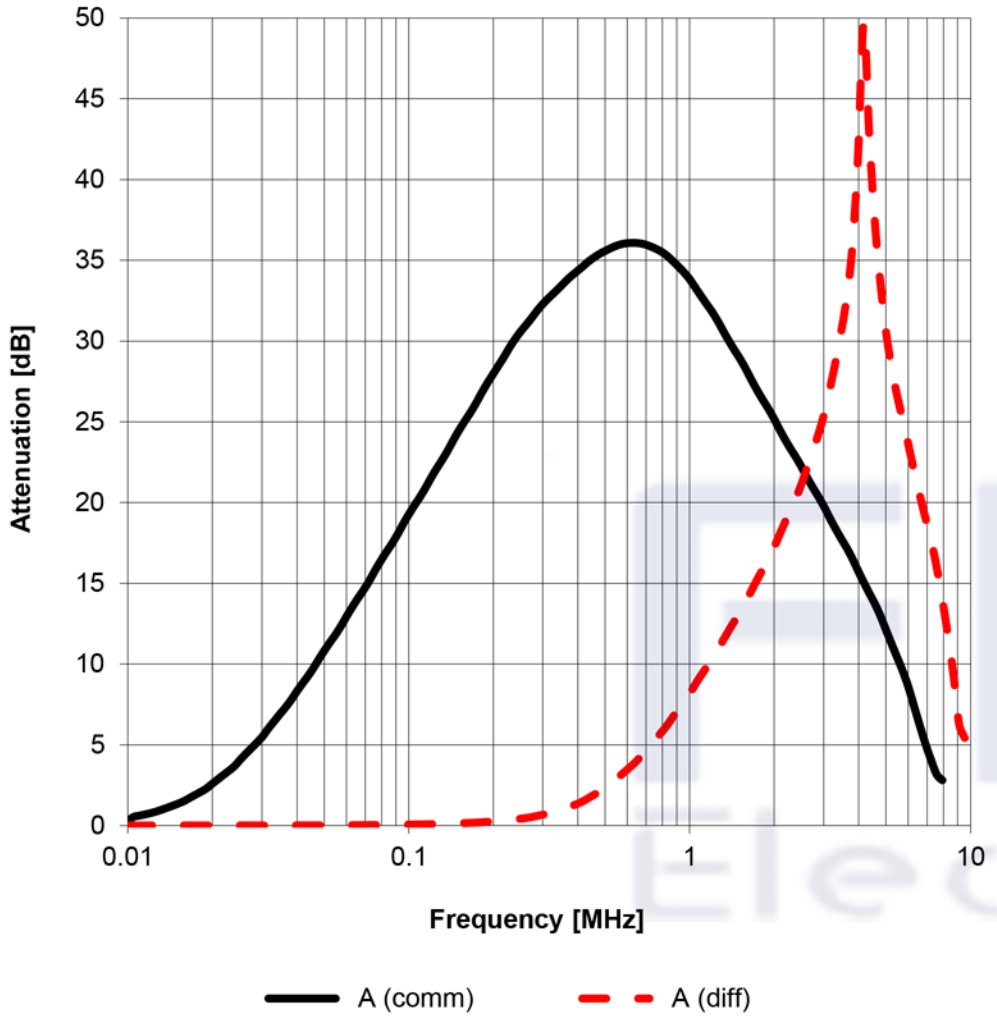

Test Setup:

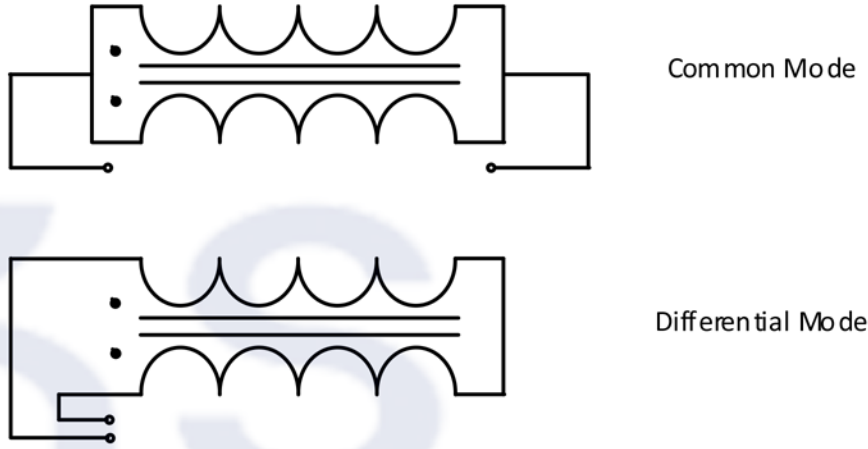

| | | | |
|---|---------------------|--------------------------------------|-----------------------|
| Shaanxi FKS Electronic Parts Import&Export Co.,Ltd. FKS(Xi'an) Electronic Technology Co.,Ltd. Address: B1 Building,Western Cloud Valley,Fengxi New Town, Xixian New Area,Xi'an City, Shaanxi Province,China. Tel: +86-29-8868 5333 Fax: +86-29-8868 0913 | | GENERAL TOLERANCE DIN ISO 2768-1m | PROJECTION METHOD |
| DESCRIPTION HV Common Mode Power Line Choke | | ORDER CODE FKS744831034090 | |
| SIZE XXL | REVISION 001.002 | STATUS Valid | |



Packaging Specification - Tray and Carton: [mm]

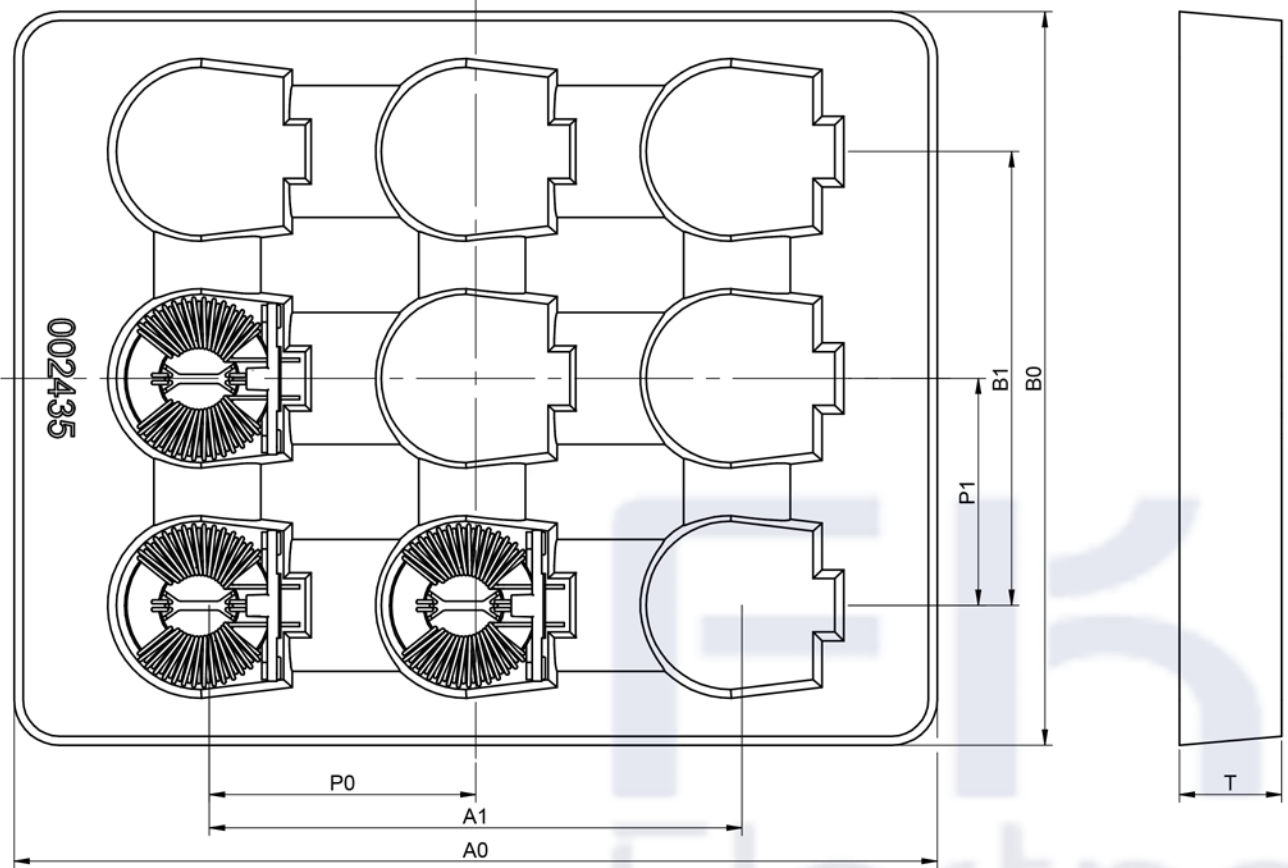

| L _{TRA} (mm) | W _{TRA} (mm) | H _{TRA} (mm) | Packaging Unit | Material |
|-----------------------|-----------------------|-----------------------|----------------|----------|
| typ. | typ. | typ. | pcs. | |
| 245,00 | 195,00 | 27,00 | 9 | PET |

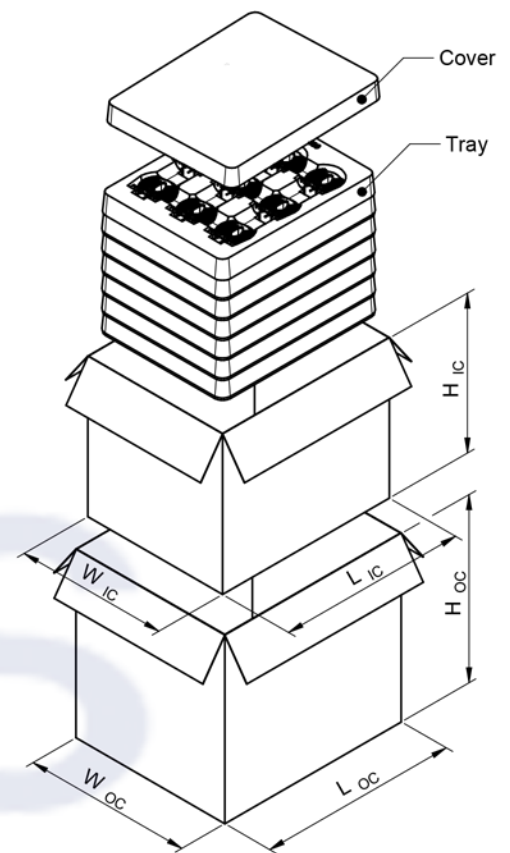

| L _{IC} (mm) | W _{IC} (mm) | H _{IC} (mm) | L _C (mm) | W _C (mm) | H _C (mm) | No. of tray | No. of inner carton | Packaging Unit | Material |
|----------------------|----------------------|----------------------|---------------------|---------------------|---------------------|-------------|---------------------|----------------|----------|
| typ. | typ. | typ. | typ. | typ. | typ. | pcs. | pcs. | pcs. | |
| 260 | 210 | 217 | 275 | 232 | 255 | 7 | 1 | 63 | Paper |

Shaanxi FKS Electronic Parts Import&Export Co.,Ltd.
 FKS(Xi'an) Electronic Technology Co.,Ltd.
 Address: B1 Building,Western Cloud Valley,Fengxi New Town,
 Xixian New Area,Xi'an City, Shaanxi Province,China.
 Tel: +86-29-8868 5333
 Fax: +86-29-8868 0913

| | | | |
|--|--|--------------------------------------|-----------------------|
| DESCRIPTION | | GENERAL TOLERANCE DIN ISO 2768-1m | PROJECTION METHOD |
| <p align="center">HV Common Mode Power Line Choke</p> | | ORDER CODE FKS744831034090 | |
| | | SIZE XXL | REVISION 001.002 |

Classification Wave Soldering Profile:

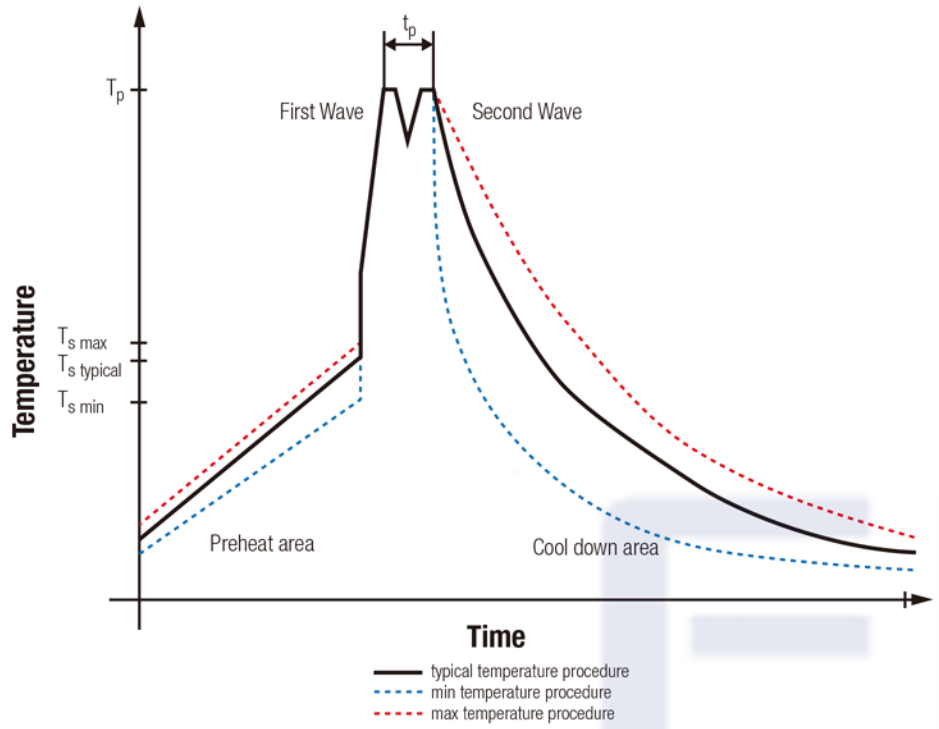

Classification Wave Soldering Profile:

| Profile Feature | | Pb-Free Assembly | Sn-Pb Assembly |
|--|-------------------------|---|---|
| Preheat Temperature Min | $T_{s \text{ min}}$ | 100 °C | 100 °C |
| Preheat Temperature Typical | $T_{s \text{ typical}}$ | 120 °C | 120 °C |
| Preheat Temperature Max | $T_{s \text{ max}}$ | 130 °C | 130 °C |
| Preheat Time t_s from $T_{s \text{ min}}$ to $T_{s \text{ max}}$ | t_s | 70 seconds | 70 seconds |
| Ramp-up Rate | ΔT | 150 °C max. | 150 °C max. |
| Peak temperature | T_p | 250 °C - 260 °C | 235 °C - 260 °C |
| Time of actual peak temperature | t_p | max. 10 seconds max. 5 seconds each wave | max. 10 seconds max. 5 seconds each wave |
| Ramp-down Rate, Min | | ~ 2 K/ second | ~ 2 K/ second |
| Ramp-down Rate, Typical | | ~ 3.5 K/ second | ~ 3.5 K/ second |
| Ramp-down Rate, Max | | ~ 5 K/ second | ~ 5 K/ second |
| Time 25°C to 25°C | | 4 minutes | 4 minutes |

refer to EN61760-1:2006

| | | | |
|---|---------------------|---|-----------------------|
| Shaanxi FKS Electronic Parts Import&Export Co.,Ltd. FKS(Xi'an) Electronic Technology Co.,Ltd. Address: B1 Building,Western Cloud Valley,Fengxi New Town, Xixian New Area,Xi'an City, Shaanxi Province,China. Tel: +86-29-8868 5333 Fax: +86-29-8868 0913 | | GENERAL TOLERANCE DIN ISO 2768-1m | PROJECTION METHOD |
| | | DESCRIPTION HV Common Mode Power Line Choke | |
| | | ORDER CODE FKS744831034090 | |
| SIZE XXL | REVISION 001.002 | STATUS Valid | |