

**Dimensions: [mm]**

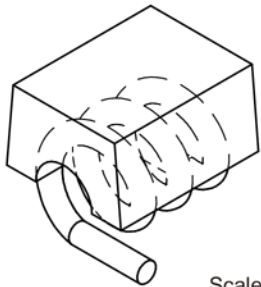

Scale - 7:1

**Recommended Land Pattern: [mm]**

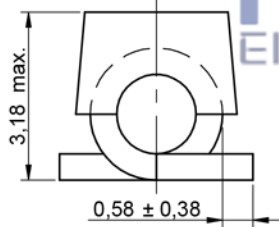
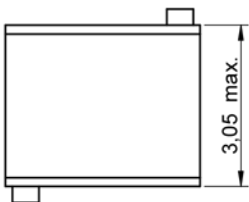
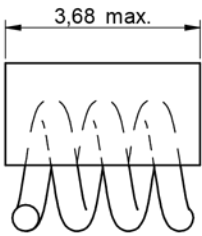
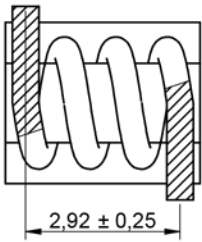
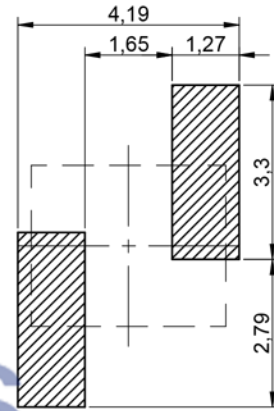

Scale - 7:1

**Schematic:**



**Electrical Properties:**

Properties		Test conditions	Value	Unit	Tol.
Inductance	L	150 MHz	8	nH	±2%
Q-Factor	Q	150 MHz	140		min.
DC Resistance	R <sub>DC</sub>	@ 20 °C	2.6	mΩ	max.
Rated Current	I <sub>R</sub>	ΔT = 15 K	4	A	max.
Self Resonant Frequency	f <sub>res</sub>		5	GHz	min.

**Certification:**

RoHS Approval	Compliant [ 2011/65/EU&2015/863 ]
REACH Approval	Conform or declared [ (EC)1907/2006 ]
Halogen Free	Conform [ JEDEC JS709B ]
Halogen Free	Conform [ IEC 61249-2-21 ]

**General Information:**

It is recommended that the temperature of the component does not exceed +125 °C under worst case conditions

Ambient Temperature (referring to I <sub>R</sub> )	-40 up to +110 °C
Operating Temperature	-40 up to +125 °C
Storage Conditions (in original packaging)	< 40 °C ; < 75 % RH
Moisture Sensitivity Level (MSL)	1

Test conditions of Electrical Properties: +20 °C, 33 % RH if not specified differently



**FKS**  
Electronics



Shaanxi FKS Electronic Parts Import&Export Co.,Ltd.  
Address:Building B1,The West Cloud Valley, Fengxi New City,  
Xixian New Area,Xianyang City,Shaanxi Province,China.  
Tel:0086 29 8868 5333 Fax:0086 29 8868 0913  
[Http://www.fks-tech.com](http://www.fks-tech.com)

DATE (YYYY-MM-DD)  
2019-05-15

GENERAL TOLERANCE  
DIN ISO 2768-1m

PROJECTION METHOD



DESCRIPTION

**Air coil**

ORDER CODE

**FKS744913080G**

STATUS

Valid

### Typical Inductance vs. Frequency Characteristics:

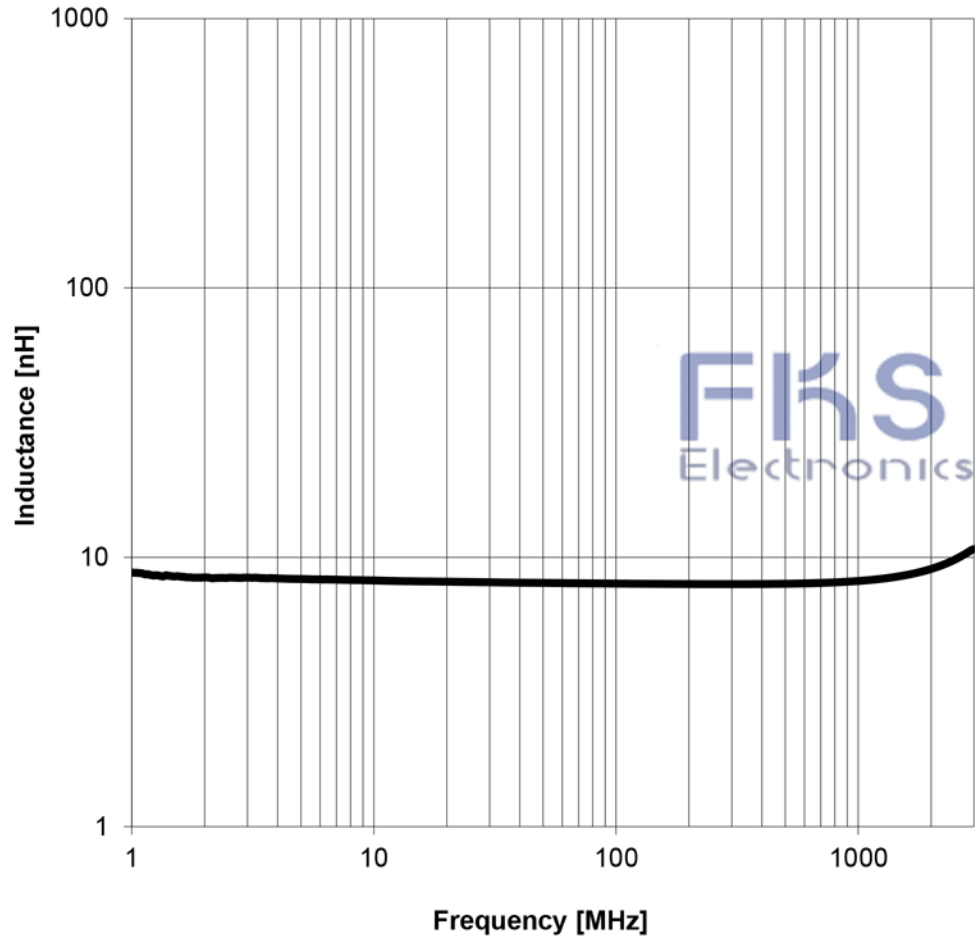

### Q-Factor vs. Frequency:

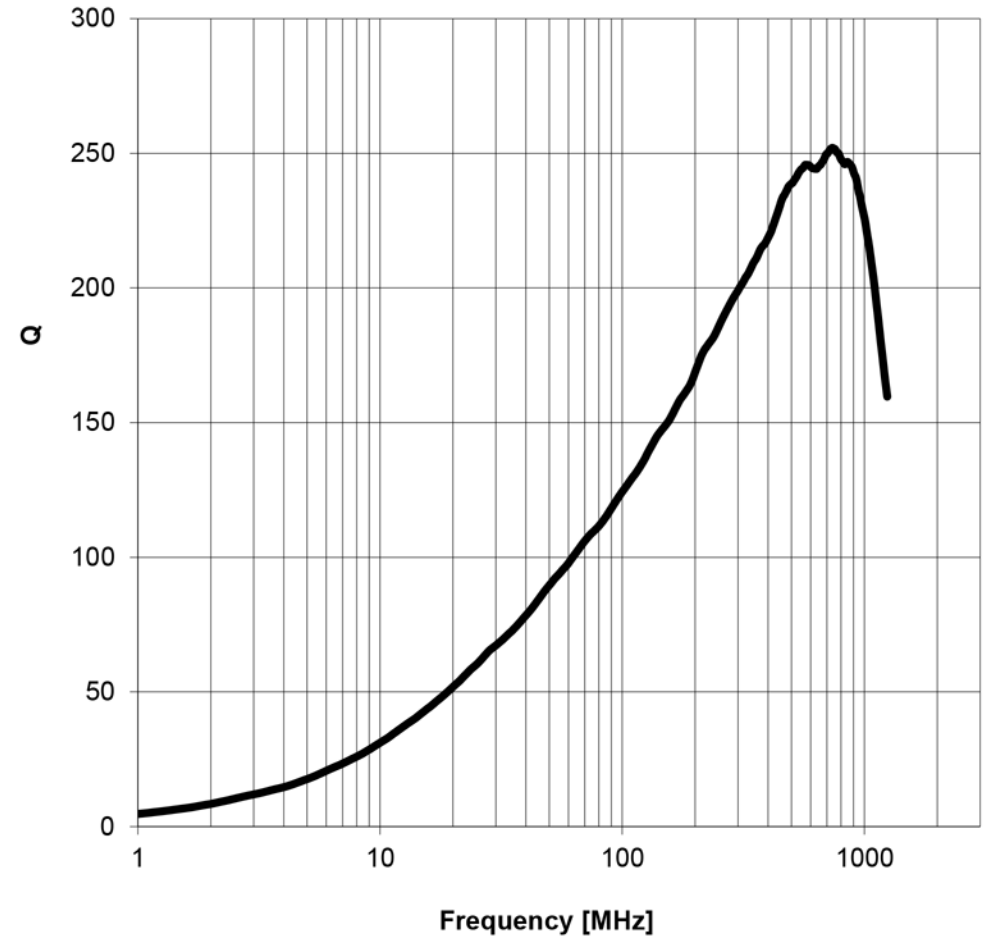

	DATE (YYYY-MM-DD) 2019-05-15	GENERAL TOLERANCE DIN ISO 2768-1m	PROJECTION METHOD 
	DESCRIPTION <b>Air coil</b>		ORDER CODE FKS744913080G
<p>Shaanxi FKS Electronic Parts Import&amp;Export Co.,Ltd. Address:Building B1,The West Cloud Valley, Fengxi New City, Xixian New Area,Xianyang City,Shaanxi Province,China. Tel:0086 29 8868 5333 Fax:0086 29 8868 0913 <a href="http://www.fks-tech.com">Http://www.fks-tech.com</a></p>	STATUS Valid		

# Packaging Specification - Tape and Reel: [mm]

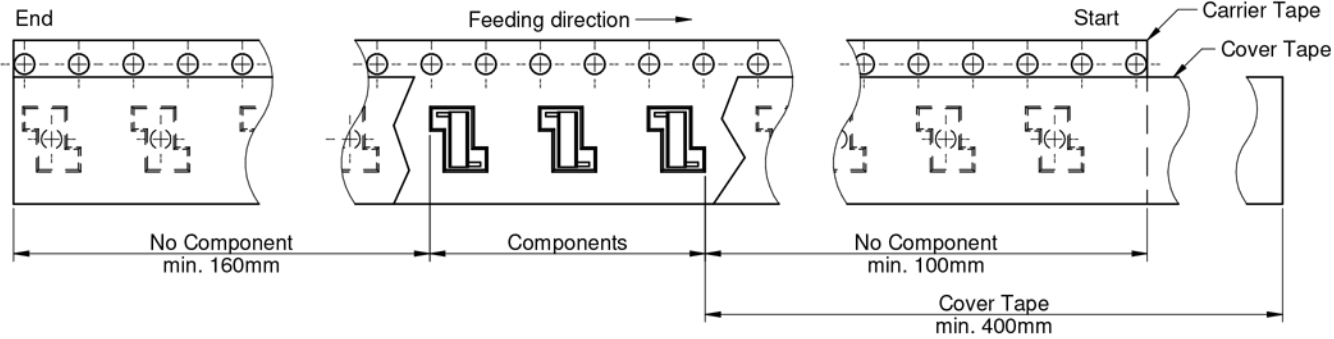
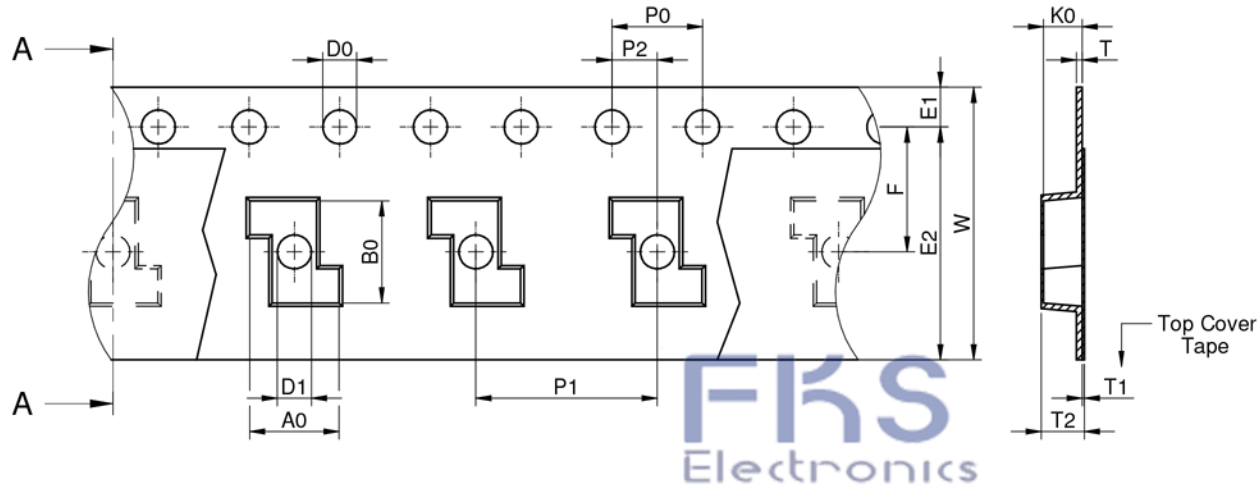

Tape Type	A0 (mm)	B0 (mm)	W (mm)	T (mm)	T1 (mm)	T2 (mm)	K0 (mm)	P0 (mm)	P1 (mm)	P2 (mm)	D0 (mm)	D1 (mm)	E1 (mm)	E2 (mm)	F (mm)	Material	Qty. (pcs.)
	typ.	typ.	+0.3/-0.1	max.	ref.	typ.	typ.	±0.1	±0.1	±0.05	+0.1/-0.0	min.	±0.1	min.	±0.05		
2a	5.80	4.50	12.00	0.60	0.10	3.45	3.25	4.00	8.00	2.00	1.50	1.50	1.75	10.25	5.50	Polystyrene	500

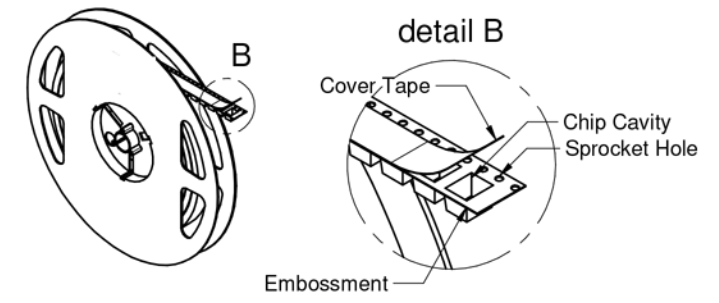
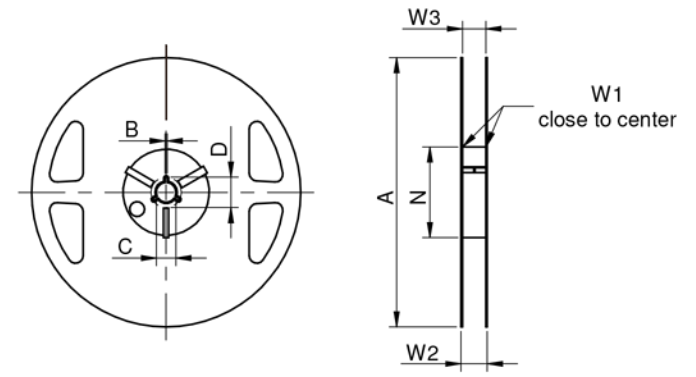

A (mm)	B (mm)	C (mm)	D (mm)	N (mm)	W1 (mm)	W2 (mm)	W3 (mm)	W3 (mm)	Material
± 2,0	min.	min.	min.	min.	+ 2,0	max.	min.	max.	Polystyrene/ Polyurethane
178,00	1,50	12,80	20,20	50,00	12,40	18,40	11,90	15,40	

	DATE (YYYY-MM-DD) 2019-05-15	GENERAL TOLERANCE DIN ISO 2768-1m	PROJECTION METHOD 
	DESCRIPTION <b>Air coil</b>		ORDER CODE <b>FKS744913080G</b>
	Shaanxi FKS Electronic Parts Import&Export Co.,Ltd. Address: Building B1, The West Cloud Valley, Fengxi New City, Xixian New Area, Xianyang City, Shaanxi Province, China. Tel: 0086 29 8868 5333 Fax: 0086 29 8868 0913 <a href="http://www.fks-tech.com">Http://www.fks-tech.com</a>		STATUS Valid

### Classification Reflow Profile for SMT components:

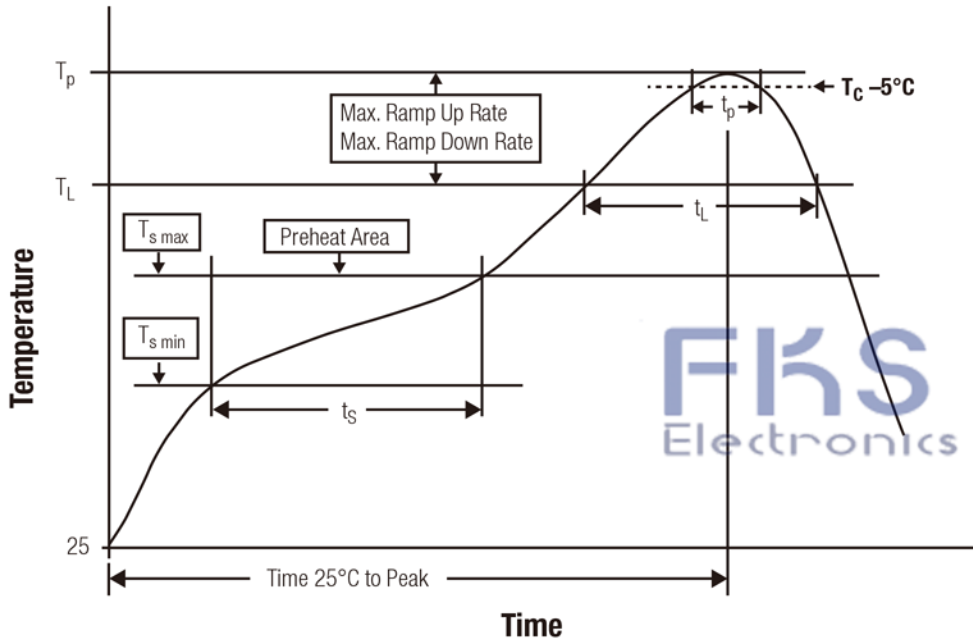

### Classification Reflow Soldering Profile:

Profile Feature		Value
Preheat Temperature Min	$T_{s\ min}$	150 °C
Preheat Temperature Max	$T_{s\ max}$	200 °C
Preheat Time $t_s$ from $T_{s\ min}$ to $T_{s\ max}$	$t_s$	60 - 120 seconds
Ramp-up Rate ( $T_L$ to $T_p$ )		3 °C/ second max.
Liquidous Temperature	$T_L$	217 °C
Time $t_L$ maintained above $T_L$	$t_L$	60 - 150 seconds
Peak package body temperature	$T_p$	see table below
Time within 5°C of actual peak temperaure	$t_p$	20 - 30 seconds
Ramp-down Rate ( $T_L$ to $T_p$ )		6 °C/ second max.
Time 25°C to peak temperature		8 minutes max.

refer to IPC/ JEDEC J-STD-020E

### Package Classification Reflow Temperature:

Properties	Volume mm <sup>3</sup> <350	Volume mm <sup>3</sup> 350-2000	Volume mm <sup>3</sup> >2000
PB-Free Assembly   Package Thickness < 1.6 mm	260 °C	260 °C	260 °C
PB-Free Assembly   Package Thickness 1.6 mm - 2.5 mm	260 °C	250 °C	245 °C
PB-Free Assembly   Package Thickness ≥ 2.5 mm	250 °C	245 °C	245 °C

refer to IPC/ JEDEC J-STD-020E



Shaanxi FKS Electronic Parts Import&Export Co.,Ltd.  
Address:Building B1,The West Cloud Valley, Fengxi New City,  
Xixian New Area,Xianyang City,Shaanxi Province,China.  
Tel:0086 29 8868 5333 Fax:0086 29 8868 0913  
[Http://www.fks-tech.com](http://www.fks-tech.com)

DATE (YYYY-MM-DD)  
2019-05-15

GENERAL TOLERANCE  
DIN ISO 2768-1m

PROJECTION METHOD

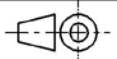

DESCRIPTION

**Air coil**

ORDER CODE

**FKS744913080G**

STATUS

Valid