

EPC17

10-Terminal, THT, Horizontal

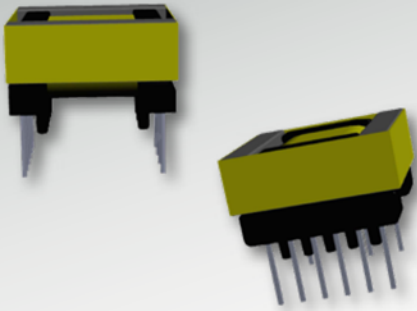

Characteristics

- Through-hole
- Core direction: horizontal
- Functional insulation

Applications

- Lighting
- Metering
- PoE
- DC/DC converter
- Industrial controls
- White goods
- Telecom

Core Data

Core Part Number	Area (A_c) (mm ²)	Path Length (L_c) (mm)	Volume (V_c) (mm ³)
150-2884	22.07	38.87	857.86

Bobbin Winding Area

Bobbin Part Number	Width (mm)	Build (mm)	Perimeter (mm)
070-5620	9.60	2.16	29.60

Dimensions & Footprint

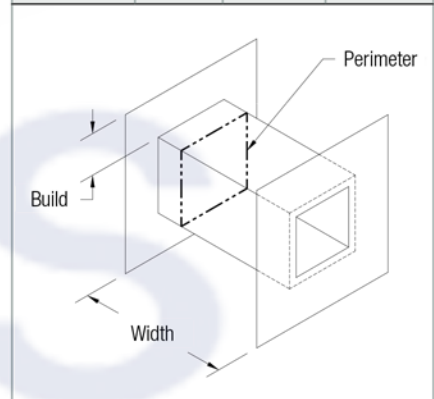
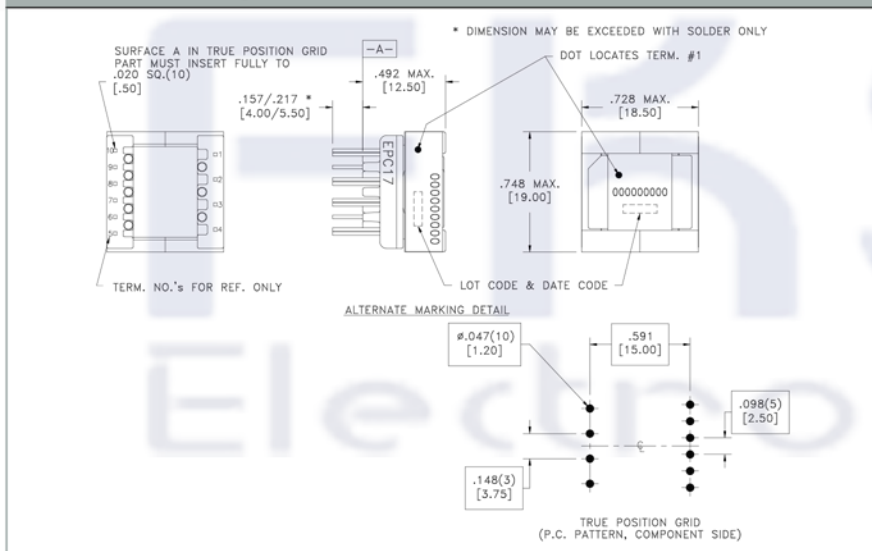

Estimated Maximum Power Level

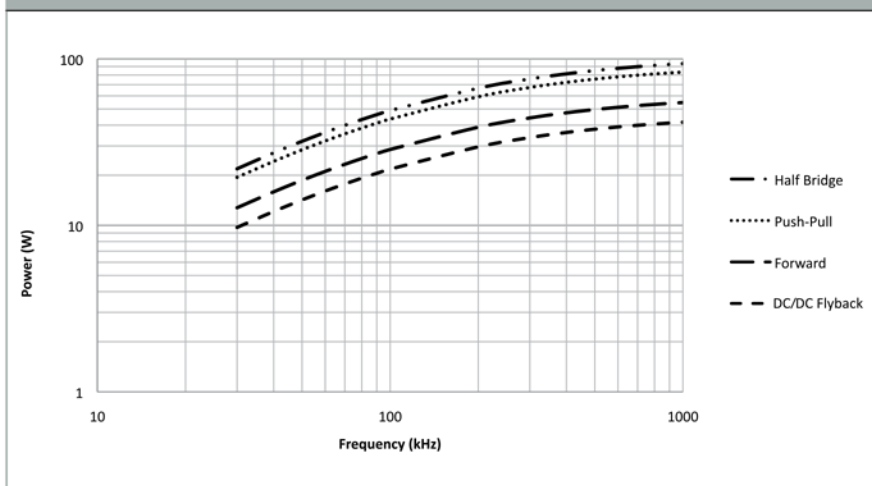

Models

- A** Altium Library
- E** Eagle Library
- S** STEP 3D Model
- I** IGS 3D Model
- W** WRL 3D Model